

NOTES:

1. FIT / FORM / FUNCTION SHALL FOLLOW PS-E.008.

BILL OF MATERIAL (CURRENT LEVEL)

ITEM	PT/ASSY	DESCRIPTION	TYPE	QTY.
1	3014	P-TRAP ASM 1-1/4" W/ BOX FLANGE	ASSEMBLY	1
2	417X	STRAIGHT VALVE W/ X HDL 1/2" SWT 3/8"	ASSEMBLY	2
3	432	SUPPLY TUBE 3/8"	ASSEMBLY	2

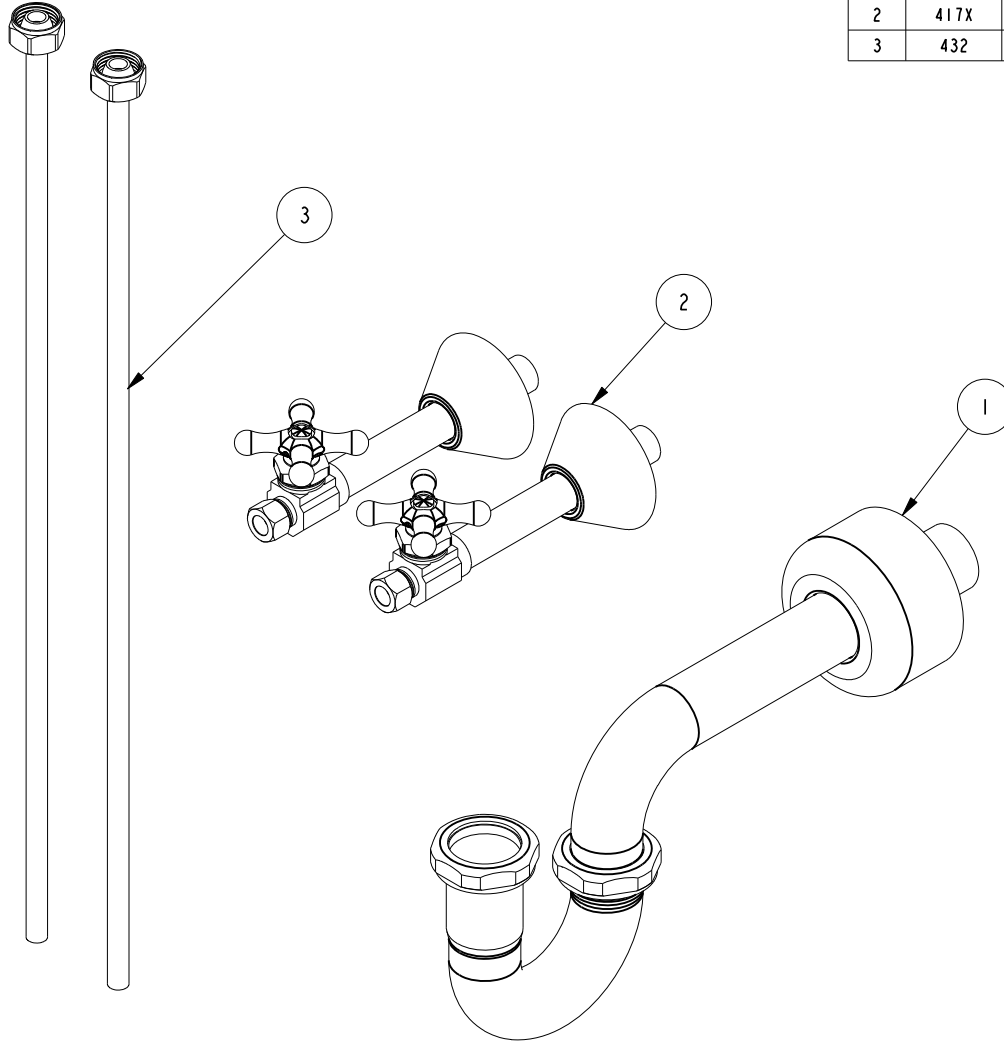

TESTING	-	-	-
ASSEMBLY	-	-	-
PLATING	-		
POLISHING	-	NEXT ASSY	USED ON
MACHINING	-	APPLICATION	
TOOLING FIXTURE #		REMOVE ALL BURRS AND SHARP EDGES	

UNITS ARE: INCHES [MM]		
TOLERANCES ARE:		
FRACTIONS	DECIMALS	ANGLES
±1/16"	.X ±.1 [2.5]	±1°
	.XX ±.06 [1.5]	
(X.XXX) DENOTES CRITICAL DIMS. ALL THREADS ARE CRITICAL		
DRAWN	RAVINDRA	07/20/15
CHECKED	JINSON	07/20/15
APPROVED	H.LE	07/20/15

BRASSTECH 2001 CARNEGIE AVE. SANTA ANA, CA 92705 (949) 417-5207
INCORPORATED

FCT CONNECTION KIT

DWG NO. **4773** REV **A**

SCALE .300 REF. - SHEET | OF |

COPYRIGHT 2005 BRASSTECH, INC. THESE DRAWINGS AND THE DESIGNS DEPICTED HEREIN ARE THE PROPRIETARY PROPERTY OF BRASSTECH. ANY USE OR REPRODUCTION IS SUBJECT TO THE EXPRESS APPROVAL OF BRASSTECH. UNAUTHORIZED USE IS STRICTLY PROHIBITED. ALL RIGHTS RESERVED.

ZONE	REV	DESCRIPTION	DATE	APPROVED
-	A	EN-3464	11/13/17	V.V.
-	-	RELEASE	07/20/15	H.LE